

STAR 9



- Compact: 360° rotation with zero tailswing.
- 8 ft 2 in (2,5 m) outreach.
- 463 lb (210 kg) platform capacity.
- Working surface of 2 m².*
- Proportional electric controls.
- High operating autonomy (9 hours).

*: with extension.

ISO 9001
GROUP
PINGUELY
HAULOTTE



ARTICULATED BOOMS



VERTICAL MASTS



TELESCOPIC BOOMS



SCISSOR LIFTS



TRAILERS

Haulotte®

ON THE UP

The Haulotte® avantages

- Full electric drive
- Narrow turning radius for excellent manoeuvrability in the most congested areas
- 32 in (0.80 m) platform extension increasing working surface
- Maximum drive speed: 5 km/h (3.1 mph)
- Gradeability up to 20%
- Driveable at full height
- Robust, reliable and easy to maintain design

STANDARD FEATURES

- 24 V electric engine
- 24 V - 300 AH traction batteries
- 30 amp battery charger
- Battery charging indicator
- 32 in (0.80 m) platform extension
- 3° tilt alarm
- 2 drive speeds
- 2 wheel drive and steer
- Free wheeling device
- Hour counter
- Horn in basket
- 2 emergency stops
- 2 control boxes
- Removable control box in basket

OPTIONS & ACCESSORIES

- Non-marking tyres
- Centralised filling
- Flashing light
- Motion alarm
- 220 V socket in basket
- Airline to cage

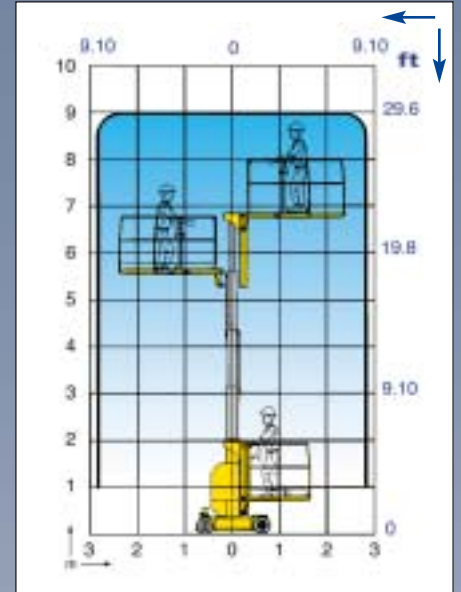
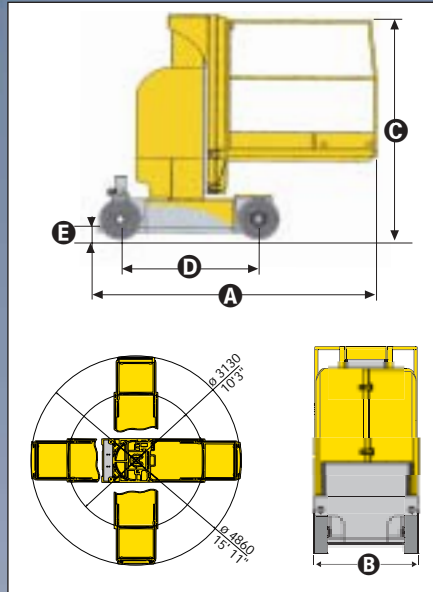

SPECIFICATIONS

Working height	9 m	30 ft
Platform height	7 m	23 ft
Horizontal reach	2.5 m	8 ft 2 in
Max. platform capacity	210 kg / 2 people	463 lb / 2 people
A Length	2.35 m	7 ft 7 in
B Overall width	1.03 m	3 ft 5 in
C Stowed height	1.99 m	6 ft 5 in
D Wheelbase	1.20 m	4 ft
E Ground clearance	10 cm	4 in
Platform dimensions	1.20 x 0.98 m	47 in x 39 in
Platform extension	0.80 m	32 in
Tailswing	0	0
Drive speed	1.1 / 5 km/h	0.68 / 3.1 mph
Raise speed (sec.)	30	30
Outside turning radius	2 m	6 ft 6 in
Turnable rotation	360°	360°
Batteries	24 V - 300 AH	24 V - 300 AH
Autonomy	9 hours	9 hours
Maximum gradeability	20%	20%
Tilt alarm	3°	3°
Solid tyres	381/114 - 203.2	381/114 - 203.2
Total weight	2350 kg	5.180 lb

